

UltraScrub™ Model of Tri-Mer's Horizontal Crossflow

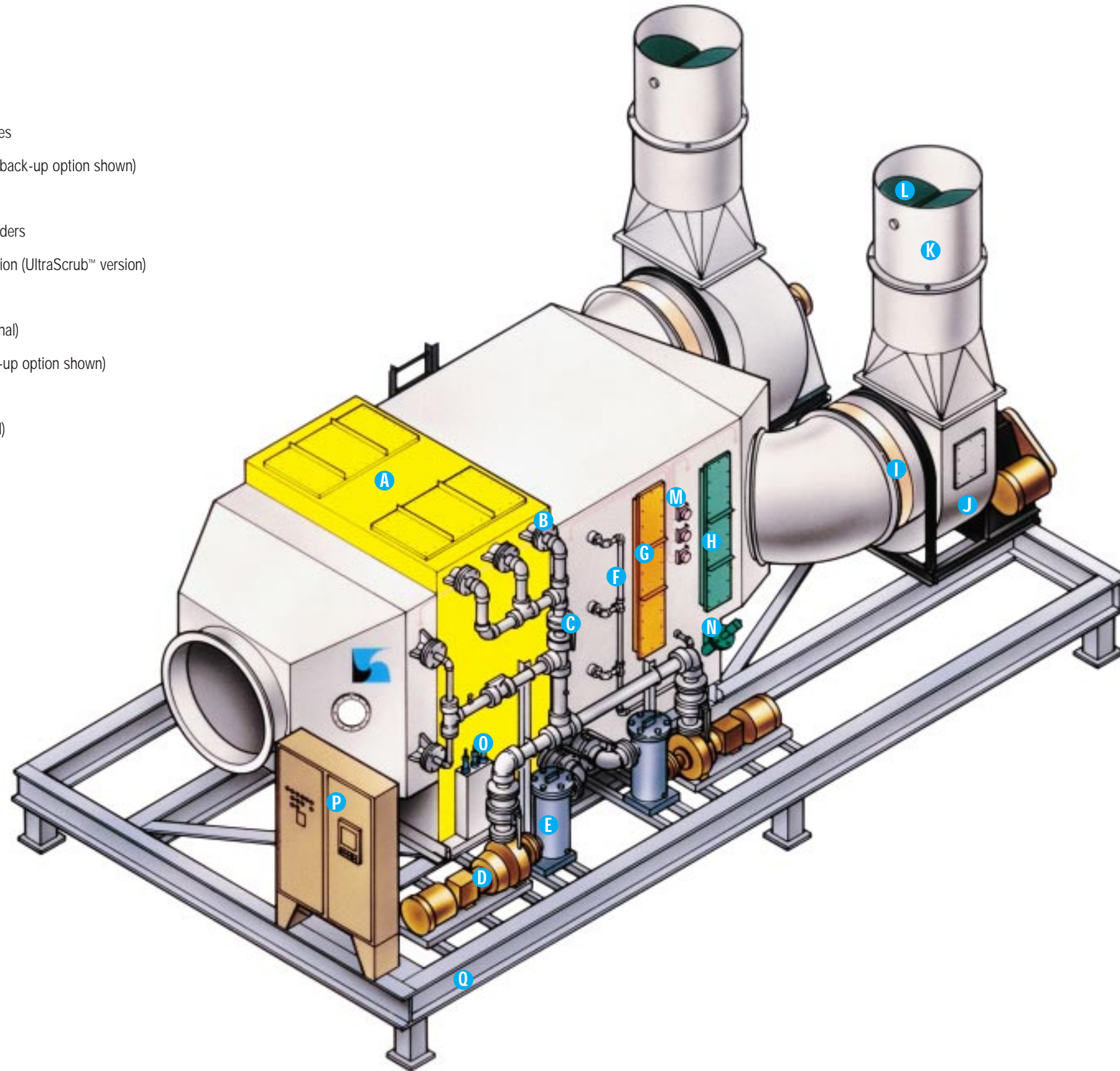

- A** Packed bed
- B** Distribution headers
- C** Recirculation piping & valves
- D** Recirculation pumps (dual back-up option shown)
- E** Basket strainers (optional)
- F** Secondary pack spray headers
- G** Second stage packed section (UltraScrub™ version)
- H** Mist eliminator
- I** Inlet control damper (optional)
- J** Exhaust blower (dual back-up option shown)
- K** Exhaust stack
- L** Butterfly dampers (optional)
- M** Pressure drop indicators
- N** pH probe
- O** Level switches
- P** Control panel
- Q** Support frame (optional)



UltraScrub™ Showing Single Fan Installation

- A** Manual or automatic damper (optional)

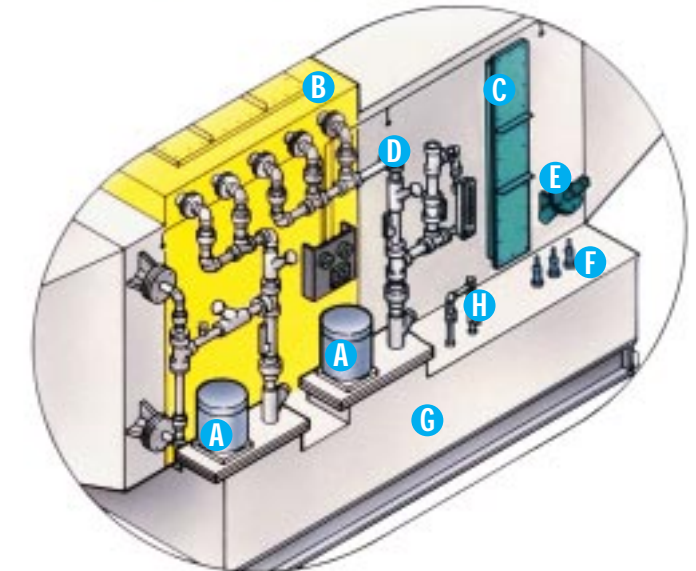
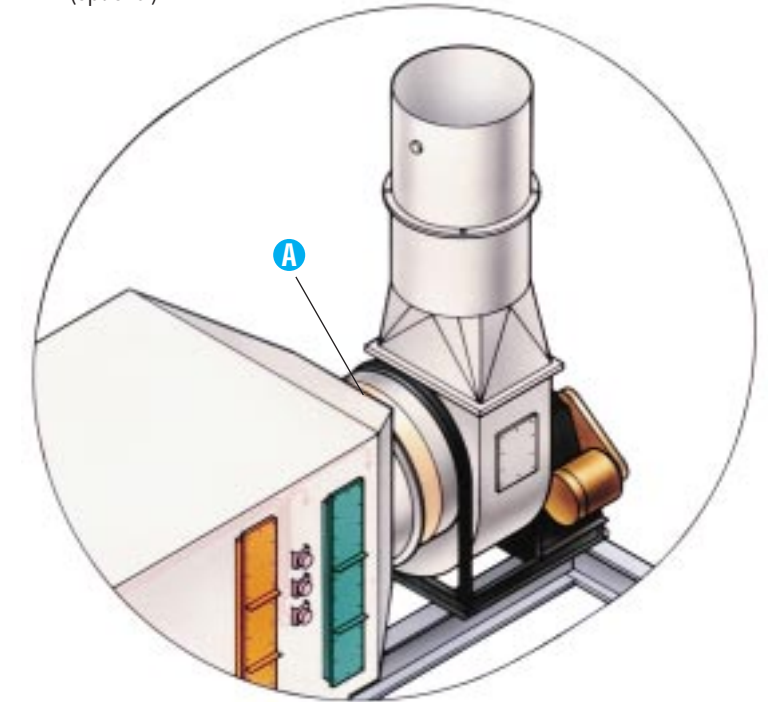

Horizontal Crossflow Scrubber – Vertical Pump Option

- A** Vertical pumps
- B** Packed bed
- C** Mist eliminator
- D** Piping package
- E** pH probe
- F** Level controls
- G** Internal recirculation tank
- H** Fresh water make-up

